

NOT TO SCALE

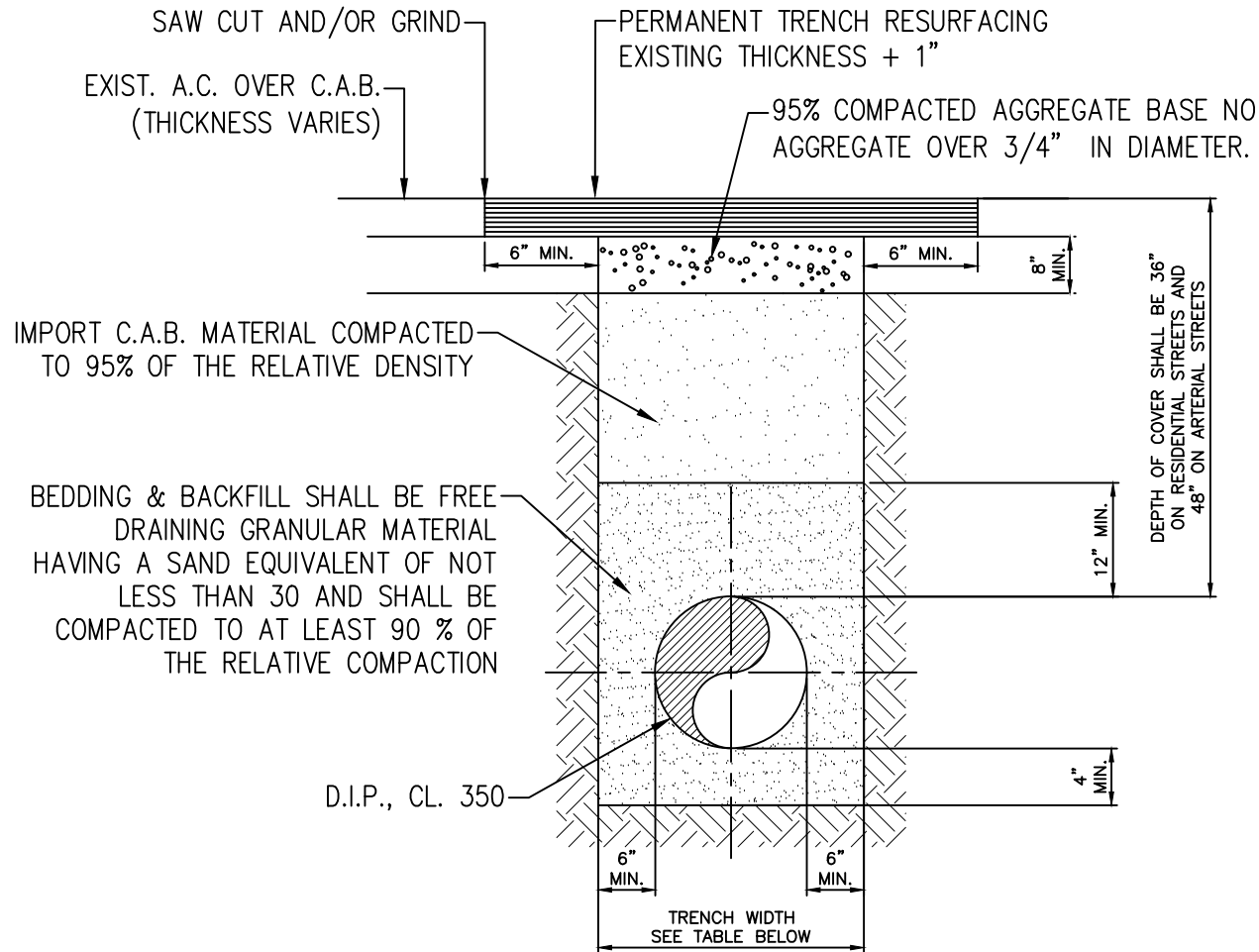

PIPE SIZE	4"	6"	8"	10"	12"	16"	20"	24"	30"
MAXIMUM ALLOWED TRENCH WIDTH	20"	20"	20"	22"	24"	28"	32"	36"	42"

NOTES:

- PERMANENT TRENCH RESURFACING SHALL CONSIST OF AN ASPHALT CONCRETE SURFACE COURSE OF TYPE C2-AR-4000 1½" THICK PLACED ON AN ASPHALT CONCRETE BASE OF TYPE B-AR-4000
- SAW CUTS SHALL BE 1½" DEEP. IF THE SAW CUT IS WITHIN 3' OF A PREVIOUS PARALLEL SAW CUT OF 3' OR GREATER IN LENGTH OR A CONCRETE EDGE, THE EXISTING PAVEMENT SHALL BE REMOVED TO SAID SAW CUT OR CONCRETE EDGE, UNLESS OTHERWISE APPROVED BY THE ENGINEER.
- THE WIDTH OF P.C.C. PAVEMENT REPLACEMENT SHALL BE A MINIMUM OF 10' WIDE AN/OR TO THE NEAREST CONSTRUCTION JOINT WITH #4 DOWELS EPOXIED @ 12" O.C.
- ANY TUNNELING UNDER EXISTING CURB AND GUTTER OR CROSS GUTTER SHALL REQUIRE A SLURRY BACKFILL TO THE SATISFACTION OF THE INSPECTOR.

TYPICAL TRENCH DETAIL

APPROVED BY:

 TOM COLEMAN
 GENERAL MANAGER
 9/15/21
 DATE



DRAWING #
 W-8
 REVISION DATE:
 SEPTEMBER
 2021

ROWLAND WATER DISTRICT

TYPICAL TRENCH
 DETAIL